

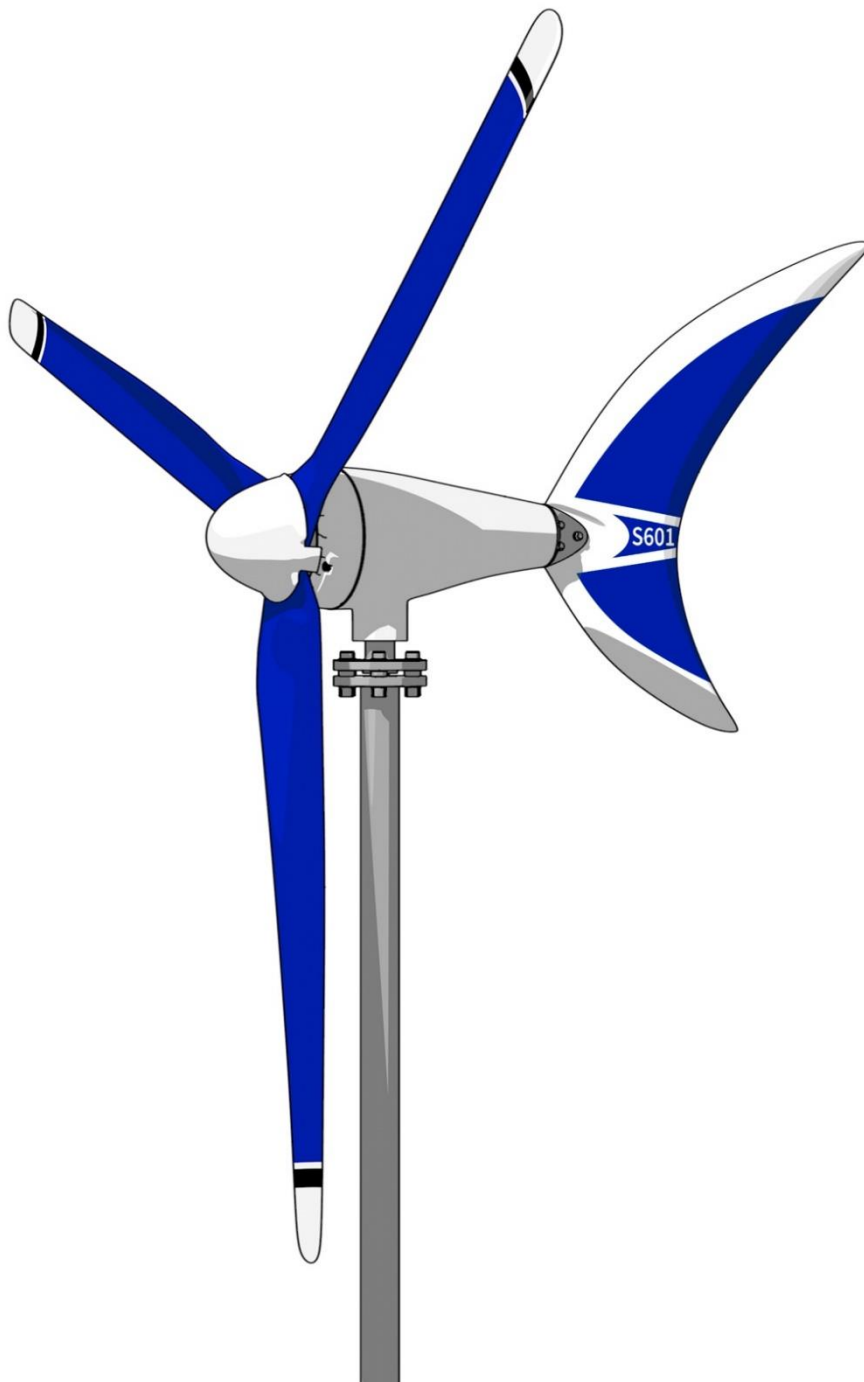

## User and installation guide

# SHARK

12V / 24V / 48V



Dear customer!

Congratulations on your decision to purchase the SHARK S601. He is distinguished from conventional wind generators with high security, enormous efficiency and very low noise level over the entire range.

You also benefit from our more than 30 years of experience with various wind generators used on the high seas (Silent Wind from Spreco on sailing boats).

Electric current is particularly important there and ensures safety and comfort on board.

Please note that this user manual is part of the product. We recommend that you read this manual carefully before installing the SHARK S601 and follow the instructions. Please keep this user manual in a safe place.

**Good luck and always enough wind wishes you your**

**Spreco Team**

## Index:

1. Use and area of application .....	4
2. Safety instructions .....	5
2.1 Mechanical hazards .....	5
2.2 Electrical hazards .....	6
2.3 Installation hazards.....	6
3. Technical data.....	7
3.1 Wind generator.....	7
3.1.1 Electrical data .....	7
3.1.2 Mechanische Daten .....	7
3.2 Charge controller .....	8
3.2.1 Electrical data .....	8
3.2.2 Mechanical data.....	8
3.4 Power curve .....	9
3.5 Dimensions .....	9
4. Scope of delivery.....	10
5. Functional description .....	11
6. Cable sizing .....	12
7. Assembly.....	13
8. Commissioning.....	17
9. Start and stop .....	19
10. Charging indicator.....	19
11. Checks .....	20
11.1 Rotor blades.....	20
11.2 Screw connections.....	20
11.3 Bearings, seals .....	20
11.4 Corrosion protection .....	21
11.5 Mast construction.....	21
11.6 Electrical System.....	21
12. Maintenance.....	22

13. Troubleshooting.....	22
14. Warranty.....	24

## 1. Use and area of application

You achieve the greatest regenerative energy yield by the combination of wind generator and solar module, whereby you save the gained energy in a battery system and thus use the daylight and the available wind energy. Our charge controller is designed to connect an additional 300Wp max. solar power (hybrid charge controller).

The possible applications are diverse and suitable for stationary and mobile stand-alone systems via the battery voltage with a 230 V inverter.

Our wind generator is very efficient and aerodynamic. If the energy requirement is higher, several SHARK S601 wind generators can be used in parallel. Due to the low noise level, the SHARK S601 wind generator can be installed in residential areas and on sailing yachts without disturbing the neighbors.

The supplied hybrid charge controller is designed with inputs for solar panels and wind generator for the SHARK S601.

Another advantage of the SHARK S601 is that almost no electronics are installed in the housing. This drastically reduces maintenance work.

The electric energy is conducted via three cables down to the regulator. The hand-laminated carbon fiber blades of the new generation have been successfully tested in the wind tunnel according to the DIN EN-61400-2 standard. You don't have to worry about the SHARK 601 in storms because a specially developed storm brake is installed. The brake procedure starts at 130 degrees C° on the stator, after cooling it is switched on again.

For maintenance work please use the enclosed stop switch.

Application examples:

Electric car charging station in connection with PV

Stationary / mobile island systems

Measuring stations on grid / off grid, Emergency call systems, Street lighting, Development aid projects, Wireless-Lan Access Points, Holiday homes with 230V (110V) inverter or wherever there is no power connection.

## 2. Safety instructions

Wind generators are due to the high speed and the voltage generated not harmless. Therefore, please read the following safety instructions with great care:

### 2.1 Mechanical hazards

The rotating rotor poses a great danger. Above a certain wind speed, it even appears transparent so that the danger is not visually recognized. Our blades are coated with three colors so that they can be better recognized visually. Never touch the rotating blades! Never try to stop the rotating blades by hand!



**Please keep your distance!**

Install the generator only in places where it is impossible for anyone to reach out to it! This is particularly important on sailing yachts. Install the wind generator at a sufficient height from the deck.

The rotor blades are made from hand-laminated carbon fiber material that can withstand even hurricane-like wind speeds. Always keep away from the rotating blades to avoid injuries.

Parts or lines flying around can still break the rotor blades. If a rotor blade is damaged, the system must be shut down by manually operating the stop switch. Damage to a rotor blade can result in significant imbalances, so that the entire mast on which the wind generator is mounted can be endangered. Please take this into account when choosing your installation site, so that it is really safe. During assembly, the three electrical cables from the generator must be disconnected and short-circuited, or a blade must be tied to the mast.

The mast and the mast struts must be such that they can withstand the wind forces and varying loads. Furthermore, the mast foot and struts should be installed in such a way that vibrations that may arise are not amplified. It is recommended to consult a specialist.

## 2.2 Electrical hazards

Only connect all components if you have the relevant experience. Complete all electrical connections before the wind generator runs for the first time. These voltages / currents can cause burns or fire if safety is disregarded.

Caution with pacemakers, etc.! Never touch stripped cable ends. The current strength when charging batteries can reach more than 50 A direct current (DC). All cables, electrical components and connection points must be able to withstand a minimum of 60 A at 12 V. For protection, a 60 A fuse at 12 V (30 A at 24 V) must be installed in the supply line (+) to the battery, as close as possible to the battery.



Warning: Lines with insufficiently dimensioned cross sections can heat up to such an extent that a fire can occur.

Cables must be laid so that there is no mechanical damage to the cables. A frayed cable poses security risks.



Warning: Sparks can occur when connecting the batteries.

Avoid short-circuiting the batteries. Always make sure there is adequate ventilation!

It must be ensured that the electrical installation is only carried out by people with expertise.

Before a storm, the SHARK S601 should be braked using the stop switch built into the charge controller. In the event of an oncoming hurricane, it makes sense if a rotor blade is tied to the mast. This is especially recommended when operating the SHARK S601 on a sailing yacht.

## 2.3 Installation hazards

Only use mast constructions that can withstand the loads generated by the wind generator and its wind pressure, as well as movements of the ship (forces can add up) at any wind speed.

Work on the mast should preferably be carried out on a windless day. No one should be in the danger area of the generator mast.



The battery must be electrically isolated from the system during all work on the system. The rotor must not run loose during work by tying up a rotor blade, otherwise the charge controller may be destroyed. The electrical installation must be completed.

### 3. Technical data

#### 3.1 Wind generator

##### 3.1.1 Electrical data

Generator type	Permanent magnet generator, 3-phase, AC
Nominal voltage	12 V DC / 24 V DC / 48V DC with boost charge controller
Rated capacity	600 Watt    700 Watt    800 Watt
Nominal wind speed	Ca. 14 m/s
Start-up wind speed	Ca. 3 m/s
Start of charging	Ca. 200 Upm

##### 3.1.2 Mechanical data

Safety test in the wind tunnel	122 km/h
Rotor diameter	1,50 m
Number of blades	3
Blade weight	250g / Blade
Blade material	Carbon Cfk Hand laminated
Speed range	200 - 950 rpm

Weight	Ca. 12 kg (Generator)
Color	White, powder coated - 2 layers
Warranty	24 Months

### 3.2 Charge controller

Charging criteria are set using the supplied external hybrid charge controller with boost function.

The charge end voltage is adjustable for lead acid, gel, AGM, and lithium batteries. Please follow the instructions of the battery manufacturer!

Braking process: electronically depending on the individual parameter setting, manually with the inbuilt stop switch or with the extended external switch.

#### 3.2.1 Electrical data

System voltage	12V	24V	48V
Max. Power input wind generator	600 W	700W	800W
Max. Current input wind generator	32 A	25A	12,5A
Max. Power input solar	300 Wp at 12 V		
Max. Current input solar	20 A	10 A	5 A
Max. Open circuit voltage input solar	18 V DC	36 V DC	72 V DC
Multi function display + LED	W, V, A, kWh, Ah,		

#### 3.2.2 Mechanical data

Weight	2.8 kg (charge controller)
Package dimensions	220 x 150 x 82 mm



Warranty

24 Months

### 3.4 Power curve

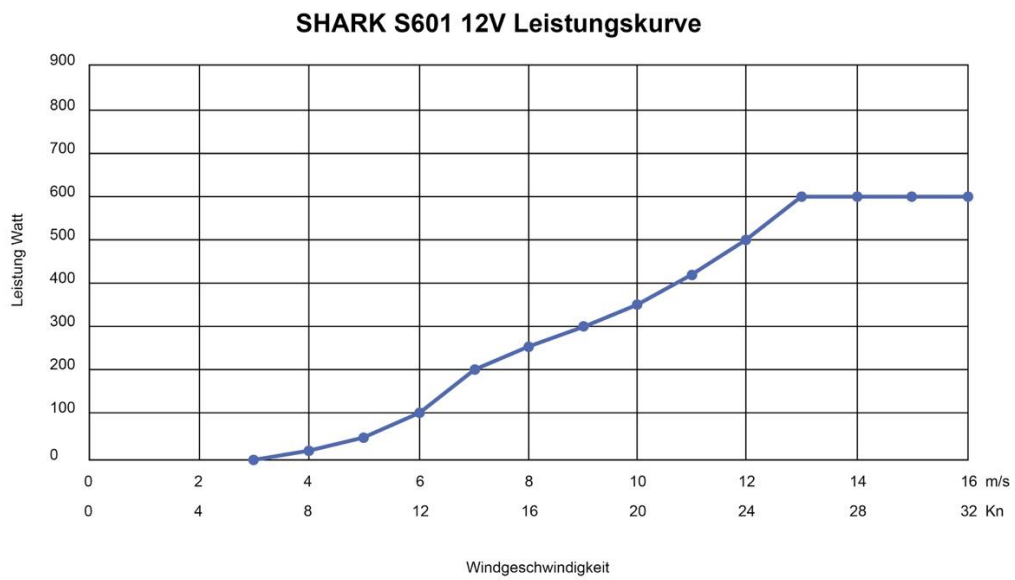

### 3.5 Dimensions

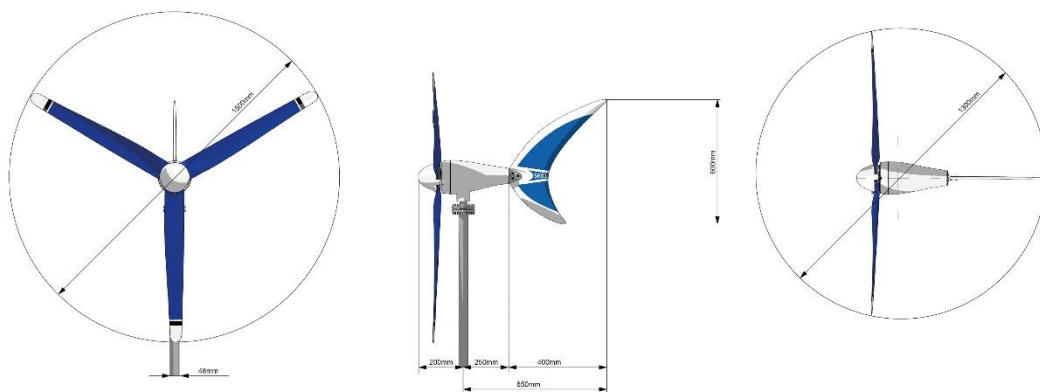

## 4. Scope of delivery

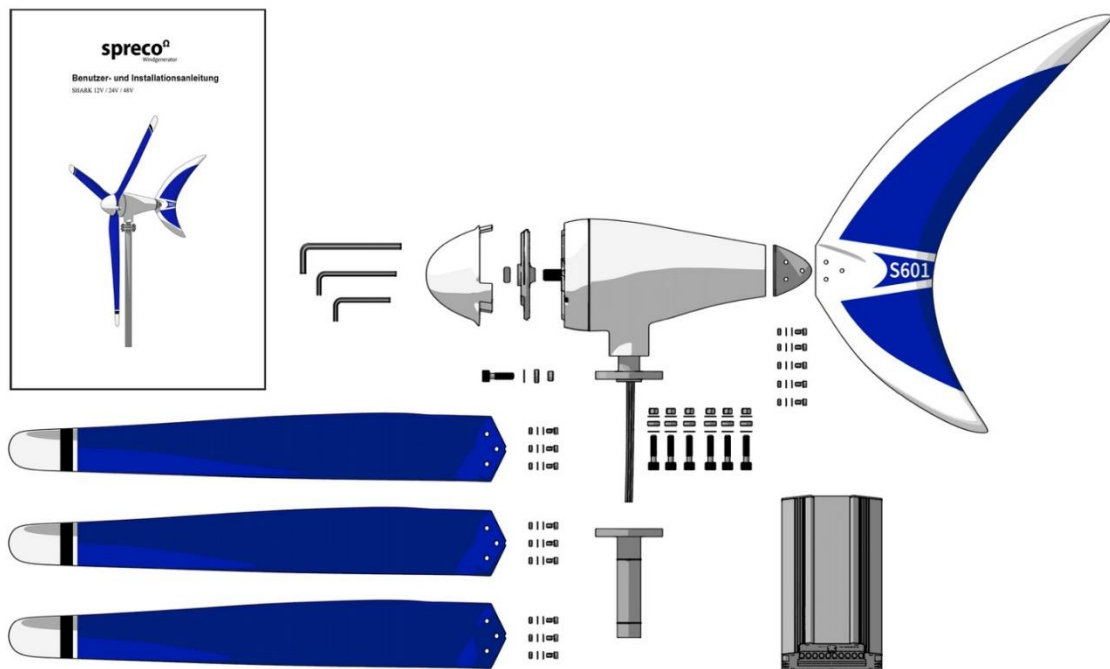

Generator, powder coated	1
Fin, Carbon	1
Hub	1
Nose cone, ABS	1
Rotor blade, Carbon	3
Boost charge controller	1
Quickguide	1
Screw set rotor blades	1
Screw set Fin	1
Allen key 4mm	1
Allen key 5mm	1
Allen key 8mm	1

All information is reliable. However, the manufacturer assumes no responsibility for inaccuracies or imperfection. The user of this information as well as the product bears full responsibility and risk.

All specifications are subject to change without prior notice.

## **5. Functional description**

All wind generators use the kinetic energy contained in the wind. This energy is partially (theoretically 58%) converted into a rotary motion by the rotor blades and then converted into a 3-phase alternating current in the generator. The power of the wind energy increases proportionally to the 3rd potency with the wind speed. That means doubling the wind speed leads to an eightfold increase in performance. This is particularly important in stormy weather.

Our rotor blades are made from high-tensile carbon fiber mats, hand laminated with epoxy resin. This material offers the highest strength with the lowest weight. As a result, the newly developed blades are extremely light and cannot be destroyed by wind forces during operation.

For normal operation, we have added additional safety to our controllers with an electronic and manual brake system.

There is also a patented strong wind brake in the generator housing. If the current is drained, the stator can heat up considerably and there is a risk of fire. the brake is then activated by a bimetal switch and, after cooling the brake is released again.

## 6. Cable sizing

### System voltage 12 Volt:

Distance from wind generator to charge controller in m	0 - 9	10 – 19	20 – 29	30 – 44	45 – 69	70 – 110
Cable cross section in mm <sup>2</sup>	6	10	16	25	35	50
AWG	10	8	6	4	2	1
Distance from charge Controller to Battery in m	0 - 9	10 – 19	20 – 29	30 – 44	45 – 69	70 – 110
Cable cross section in mm <sup>2</sup>	10	16	25	35	---	---
AWG	8	6	4	2	---	---

### System voltage 24 Volt:

Distance from wind generator to charge controller in m	0 - 10	11 – 19	20 – 29	30 – 44	45 – 69	70 – 110
Cable cross section in mm <sup>2</sup>	2.5	4	6	10	16	25
AWG	14	12	10	8	6	4
Distance from charge controller to Battery in m	0 - 9	10 – 19	20 – 29	30 – 44	45 – 69	70 – 110
Cable cross section in mm <sup>2</sup>	10	16	25	35	---	---
AWG	8	6	4	2	---	---

### System voltage 48 Volt:

Distance from wind generator to charge controller / inverter in m	0 - 29	30 – 79	80 – 99	100 – 150
Cable cross section in mm <sup>2</sup>	2.5	4	6	10
AWG	14	12	10	8
Distance from charge controller to Battery / Inverter in m	0 – 29	30 – 69	70 – 99	100 – 150
Cable cross section in mm <sup>2</sup>	4	6	10	16
AWG	12	10	8	6

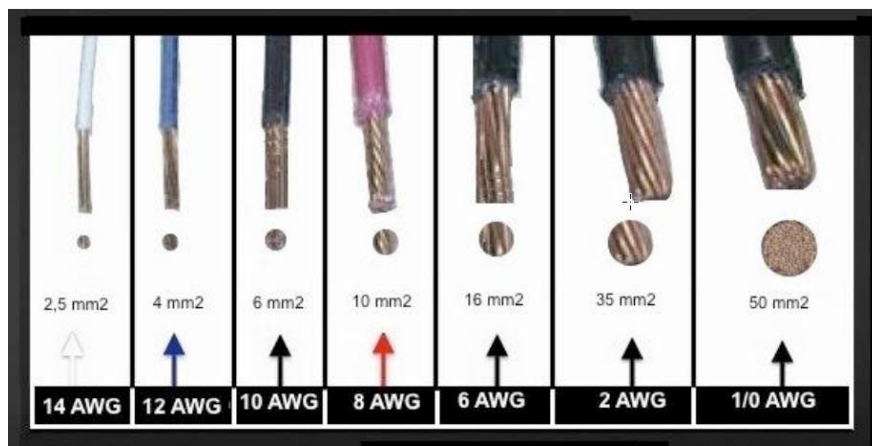

## 7. Assembly

Before the wind generator assembly, you should find the right location. This is often the most difficult task. Ideal would be if the rotor blades were always flowed evenly. This presupposes that the wind generator is installed high enough and free of obstacles.

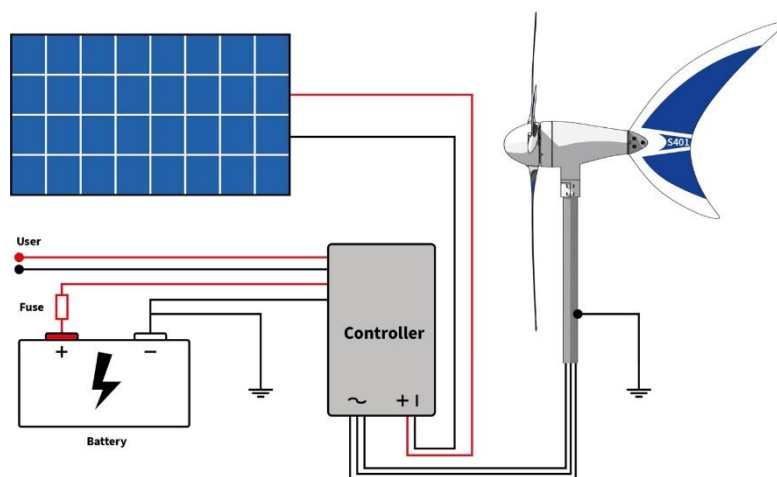

*Electrical installation example*

**Stationary assembly:** The required assembling height depends on how much the surrounding objects deflect the wind from his main direction. To do this, you can first carry out a simple experiment by attaching a plastic tape (approx. 3 m long and 4 cm wide) to a rod that is at least 4 m long, at the upper end and additionally attach a second tape two meters lower.

If the top band blows perpendicularly or moves back and forth up to 30 degrees, you have found a suitable location. If the tape moves more or even winds around the rod, the location is unsuitable. This experiment is only a rough statement and should only be carried out with light wind. We recommend doing several tries to get a better feel for it. You do not need to do this if the wind generator is completely free.



**Assembly on a sailing yacht:** The assembling height must be chosen so that no crew member is endangered by the rotor. The mechanical anchoring of the base point of the generator mast must be able to withstand the mechanical loads that occur, especially with rough seas. We advise an additional rigging, to the rail or to the deck of the ship. In order to avoid vibrations, we recommend to set the mast fixation point about 25 cm below the blade tip.

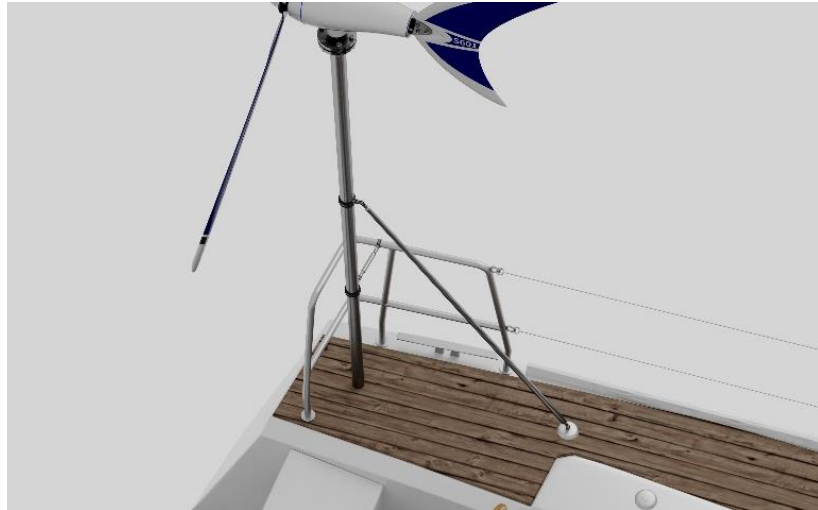

Note: Please note that the SHARK S601 can never achieve its full performance if it is not in the main wind direction or is deflected. Therefore, it is important to find a suitable location that is free of obstacles in the prevailing wind direction!

Once you have found the right location, the right mast with accessories must be selected.

The mast outer diameter should be 48 mm and made of stainless steel, with a wall thickness of at least 2.5 mm. Please also consider possible maintenance work. Grounding the mast is also recommended. The grounded sail mast is suitable on sailing yachts.

When the mast is installed in the correct location, the relatively simple assembly of the SHARK S601 can begin. To do this, first mount the three carbon fiber blades with the respective screw set on the Hub. Note - The screws must be properly tightened (the tightening torque is 7 - 8 Nm.) Please see our videos in the download area.

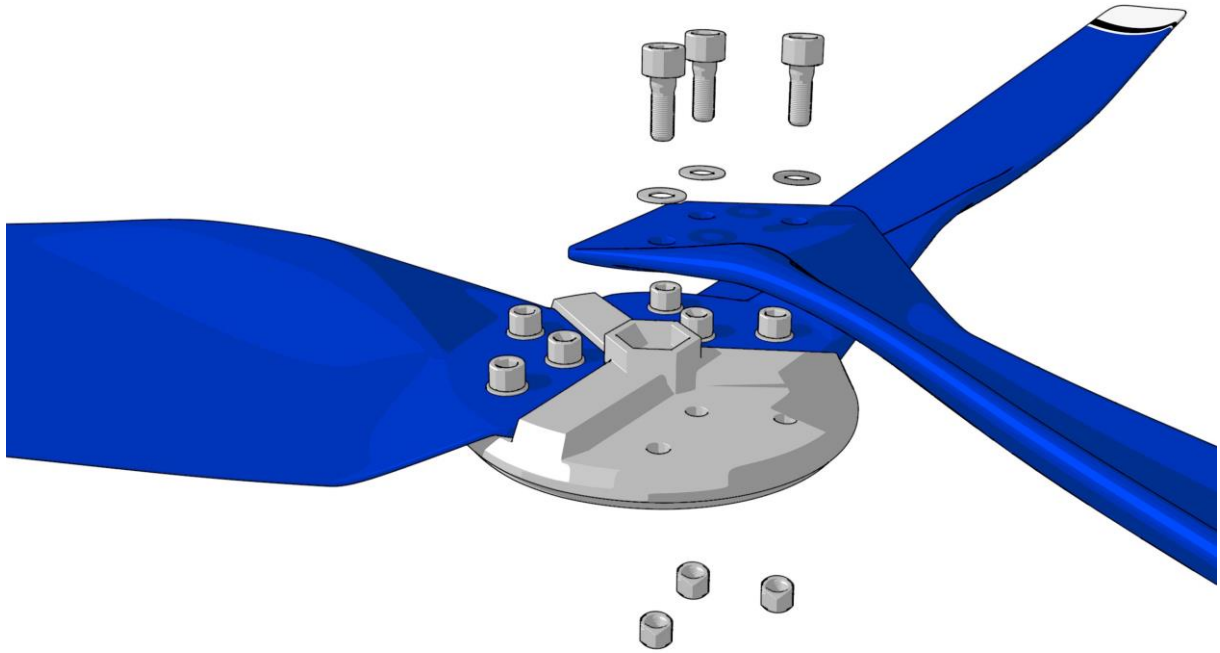

An incorrect tightening torque represents a considerable safety risk. Check the rotor blades regularly for tightness, optically and mechanically!

Should it happen that a blade is damaged by external influences, a single blade can be ordered by notifying the exact weight of the remaining good blades.

After the blade assembly, the blade set is plugged onto the generator axis and screwed down with the enclosed nut and Allen key. Then press the nose cone onto the Hub until it is fully engaged (see assembly video).



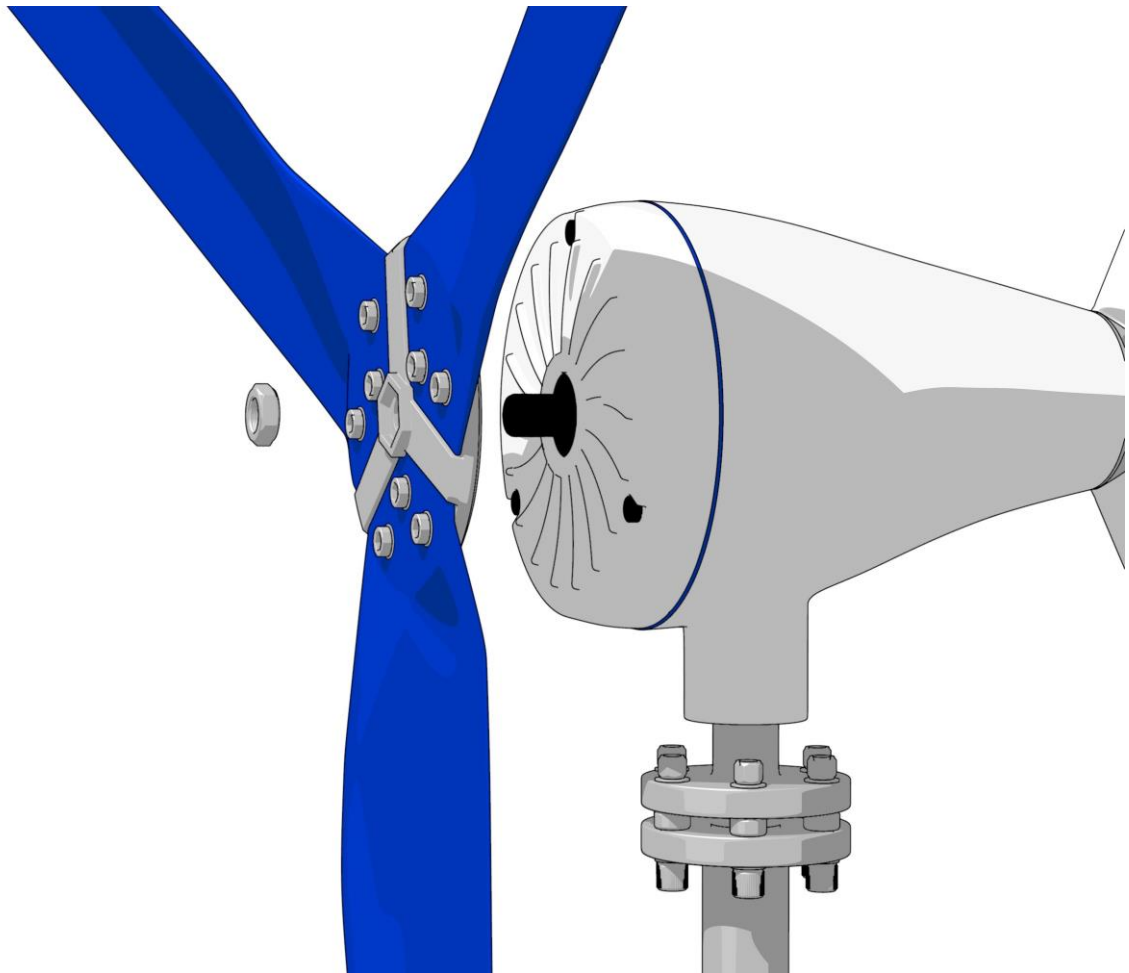

Attention: During this work on the rotor it must be ensured that the rotor cannot start. The 3 wired cable must be short-circuited. Otherwise, the rotor can start running and cause injuries.

If you remove the SHARK S601 from the mast to replace the rotor blades, you must ensure that the blades do not start moving before you have finished the work (3 AC cable short circuit).

## 8. Commissioning

Before releasing up your SHARK S601, please check the correct assembly and installation using the following checklist:

O.K.	<p>Inspection</p>
	<p>Mast construction (not included);</p> <p>Check according to the enclosed instructions, in particular all screw connections, anchoring, vertical alignment.</p> <p>Earthing and lightning protection connected according to local regulations?</p>
	<p>Electrical installation:</p> <p>Check the condition of the battery and connect it to the charge controller with the correct polarity</p>
	<p>Charge controller:</p> <p>Is the charge controller securely attached to the installation site? (Choose cool place)</p> <p>Connect the battery with the correct polarity, otherwise the controller will be destroyed. Caution: Always connect the battery to the charge controller first!</p> <p>Are all screw terminals tightened?</p> <p>Is the external stop switch set to ON?</p> <p>CAUTION: No voltage may be applied to the stop switch socket !! This destroys the controller. Only connect the enclosed cable harness with socket there. (see installation video in the download)</p>
	<p>Automatic circuit breaker:</p> <p>Automatic circuit breaker, at least 60 amps, connected between battery and charge controller?</p>
	<p>Cables:</p> <p>Are all cables / lines connected according to the connection diagram?</p> <p>Is the cables polarity checked at all connection points?</p> <p>Is the three-pole cable from the generator to the charge controller connected?</p> <p>Are the cables crimped correctly?</p>

	<p>Mast mounting:</p> <p>Is the damping rubber correctly screwed to the flange and checked for tightness?</p>
	<p>Rotor blades:</p> <p>Is the assembly carried out according to the instructions?</p>
	<p>Blade Hub:</p> <p>Is the hub mounted on the generator shaft?</p> <p>Has the central fastening screw been tightened to 30 Nm?</p>

If our charge controller is not used:

Connection to the three-phase rectifier (optionally available from us in the shop) can be found in the package Leaflet. This enables you to provide the energy generated by the wind generator to downstream systems. e.g. Inverter input, energy management systems, island systems.

## **NOW YOU CAN GET STARTED!**

### **9. Start and stop**

Set the external stop switch to “ON”. If the plus / minus cable is connected to the battery with the correct polarity, the wind generator should now run if there is enough wind available. You can see this on the LCD display of the charge controller. (blade symbol turns). Small stop switch should be provided by the customer or optionally ordered from us in the shop.

### **10. Charging indicator**

The amount of charge is shown on the charge controller display.

## 11. Checks

Your SHARK S601 is designed to last for years without any maintenance. However, simple and regular checks are always part of it to ensure the necessary operational safety.



Your safety is very important to us!

Before you start the check, make sure that during all work on the system, the rotor is brought to a standstill and the battery is disconnected from the system.

The following checks should be carried out every 12 months:

### 11.1 Rotor blades

Check the rotor blades for possible damage, such as broken edges, surface damage, cracks. If you find any damage, the generator must not be operated. Check the screw connection after one day of operation and then after one month. You can then switch to longer intervals.

### 11.2 Screw connections

Check all screw connections that are accessible from the outside for tightness or correct tightening torque. Check the rotor blade bolts, the central hub nut and the mast attachment in particular.

### 11.3 Bearings, seals

The bearings of the generator shaft and the bearing for the Yaw shaft are designed as permanently lubricated ball bearings. Please check these bearings for ease of movement, bearing play and tightness. Please replace defective bearings or have them replaced by a service center. The Shark rotor is supported on both sides and therefore has a longer service life and is quieter.

## 11.4 Corrosion protection

All housing parts consist of a seawater-proof aluminum alloy and are additionally treated with a powder coating (2-layer structure). If this layer is damaged, there is a risk of corrosion. Please touch up with a suitable varnish.

## 11.5 Mast construction

ACHTUNG



The Shark S601 flange must be attached to the mast! Either with 2 screws (picture 1) or welded on (picture 2).

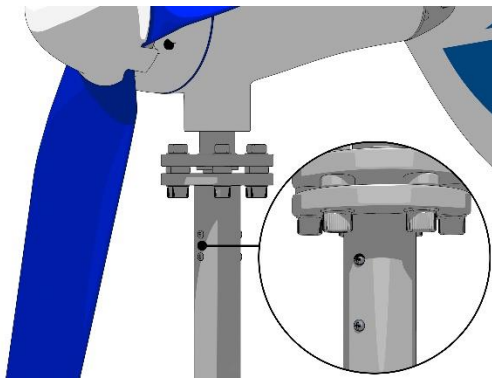

*SHARK attached with 2 screws*

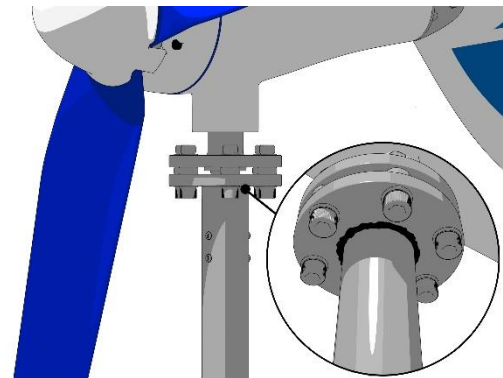

*SHARK welded to the mast*

## 11.6 Electrical System

Please bring the wind generator to a standstill first so that all lines are free of voltage.

Check all connection points for tight fit and corrosion. Correct any corrosion that may have occurred and treat with contact spray. You should pay particular attention to the battery connections. These are to be cleaned and treated with pole grease. The battery must be checked and repaired according to the manufacturer's instructions. If there are several batteries, you should also check for different capacities (self-discharge). Only connect the same size (Ah) and the same aged batteries in parallel!

## 12. Maintenance

There is no maintenance work on the SHARK S601.

The SHARK S601 was designed for years of trouble-free operation. This goal was very important to us.

## 13. Troubleshooting

You should be able to solve a problem yourself with the following checklist:

### Wind generator does not start:

Possible cause	Test	Fix
Stop switch is set to "STOP"		set to "RUN"
Generator shaft stiff	turn by hand	Connecting cable Generator to charge controller damaged, Short circuit of AC-Electric wire, Generator short circuit, Customer service

### Wind generator does not deliver power:

Possible cause	Test	Fix
Too low wind	measure wind speed at rotor height.  (Wind speed at the top of the main mast is higher)	Wait for more wind, charging starts depending on the charge level of the Battery, Check charge controller setting
Electrical conductance is broken	Check conductance of cables and devices	Replace defective cables or devices

Fuse interrupted	Check conductance of fuse	Replace fuse, or wait for automatic circuit breaker to cool down
Built-in Current collector (slip ring unit) has no contact	Check carbon brushes and springs in the housing	Replace carbon brushes, make springs usable

**Battery is not fully charged:**

Possible cause	Test	Fix
Battery old, defective	Battery voltage and capacity with Battery tester (Hardware store available) check.	Replace battery, refill distilled water (not with gel or AGM battery)
Fuse defective	Check conductance	Replace the defective fuse and find the reason for the defect
Charge controller incorrectly connected	check according to plan	connect properly
Charge controller, stop switch is set to "STOP"	Set the stop switch to "ON"	Follow instructions in manual
Generator defective, cable short circuit	Check AC voltage at the input of the charge controller	After disconnecting the charge controller, check all three cables for short-circuit interruptions
Charge controller defective, battery reverse polarity	Check settings according to manual	Repair, Customer service, replacement

## 14. Warranty

The company Bach Energiesysteme guarantees that all of the devices it sells have no defects in materials and workmanship within the warranty period from the time of purchase.

The following warranty periods apply:

**SHARK S601**                      **24 Months**

**BOOST charge controller**    **24 Months**

Should defects in the device become apparent during this period, which can be attributed to material or processing errors, Bach Energiesysteme will repair or replace the device itself or defective parts in accordance with the following conditions, without calculating the labor and material costs.

Warranty services are only provided if the warranty certificate in the appendix to these installation instructions is completely filled out and the original invoice from the dealer is presented.

**The warranty does not cover:** Regular inspections, maintenance, repair or replacement of parts due to normal wear and tear.

Transport, freight costs and freight risks that are directly or indirectly related to this device guarantee.

Travel expenses to and from the repair center, troubleshooting, diagnostics and repair work.

Damage caused by misuse and failure to operate the device, especially when installed on an unsuitable mast. In the event of damage, the buyer must provide proof that the installation was carried out on a suitable mast.

Damage caused by force majeure or other causes for which Bach Energiesysteme is not responsible, in particular lightning strikes, flooding, snow loads, fire, hurricanes, etc.

If the delivery item has to be dismantled as part of the warranty and rebuilt after repair or replacement, dismantling and reconstruction costs will not be borne by Bach Energiesysteme. Bach Energiesysteme company alone decides whether repairs or new deliveries are appropriate or necessary. If neither repairs nor new deliveries are possible, the client is only entitled to withdraw.

Unless mandatory law provides otherwise, the buyer's claims against Bach Energiesysteme are limited to these warranty provisions, and neither Bach



Energiesysteme nor the distributors of the products assume liability for direct or indirect damage.

Otherwise, the "General terms of delivery for products and services of the electrical industry" apply in Germany.

Name	
Adress	
Purchase date	
SHARK S601 Serial Nr.	
Boost Charge Controller Serial Nr.	
Dealer	
Dealer adress	

### **SPRECO Windgenerator**

Bach Energiesysteme

Brand 74

D-91729 Haundorf

Telefon: +49 (0)4193/8709925

Telefon: +49 (0)9837/9769838

Mail: [support@sprecowindgenerator.com](mailto:support@sprecowindgenerator.com)

Web: [www.sprecowindgenerator.com](http://www.sprecowindgenerator.com)